



Exceptional Performance in Any Environment

ACCENT IFRS 36 SEPARATOR

The IFRS 36 is a unique 36" rotary screen separator specifically designed for hog and dairy manure. Suitable for all types of bedding material including SAND, the IFRS 36 has a proven track record for reliability and efficiency. With exceptional performance in both flush and scrape manure conditions, the IFRS 36 delivers superior capacities and outstanding solid capture. The IFRS 36 is also ideally suited for operation within a bio-digester system as a thickener and dewatering unit.

STAINLESS STEEL CONSTRUCTION

Built with pride using precision equipment and the highest quality stainless steel, the IFRS 36 will work well and look great for years to come. Using state of the art CNC processes and the latest technologies in design and engineering the IFRS 36 will deliver the performance you need. Farmers know the benefits of stainless steel. So do we, that makes Accent Manufacturing the leader in the industry.

SIMPLICITY. VERSATILITY. DURABILITY.

Simplicity of design with no belts or chains provides reliable operation and low maintenance. Rugged construction, wear resistant materials and quality components ensures the **Durability** you need. Dairy or hog, thick or thin, flush or scrape, sawdust or sand – the IFRS 36 has the **Versatility** to perform in any type of manure or system. At Accent our experience tells us simple is better, and now with thousands of hours of demanding service and satisfied customers... we've proven it.

www.accentmanufacturing.com



Accent Manufacturing Inc.
602 - 30731 Simpson Road, Abbotsford, British Columbia, Canada V2T 6Y7. Tel: 604.850.7799. Fax: 604.850.7909.
E-mail: info@accentmanufacturing.com

Accent IFRS 36 Separator

RECOMMENDED BY USERS AS THE BEST

Listed below are the many features and benefits of the Accent IFRS 36 Separator. These engineered separators are designed to make the equipment versatile for multiple applications and durable for many years of trouble-free use and cost effectiveness. This careful attention to detail is what makes Accent the first choice for investment among farmers and manure management consultants around the world.

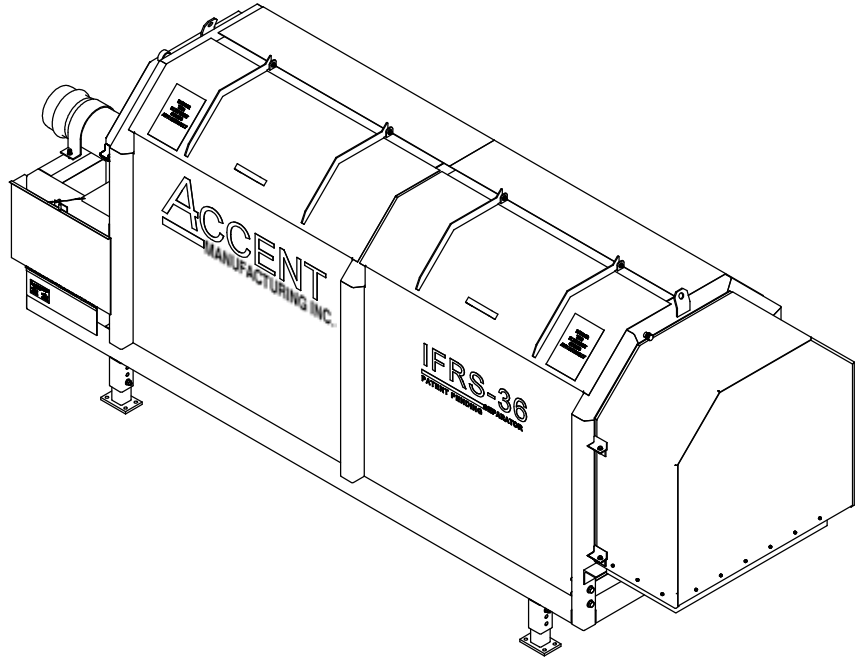

Features	Benefits
<ul style="list-style-type: none"> ■ Mounting Legs <i>Variable Position</i> 	<ul style="list-style-type: none"> ■ Adjustable to regulate for bypass flow ■ Maximizes solid matter dewatering
<ul style="list-style-type: none"> ■ Vector Drive VFD / Gearbox <i>Variable Speed Control & High Torque Starting</i> 	<ul style="list-style-type: none"> ■ Maximizes thru put capacity ■ Ensures positive high load starting ■ Facilitates low speed ramp up starting
<ul style="list-style-type: none"> ■ Delrin Engineered Bearings <i>One piece machined bearing blocks</i> 	<ul style="list-style-type: none"> ■ Requires no lubrication ■ Trouble- free operation
<ul style="list-style-type: none"> ■ Drive Wheels <i>One piece solid stainless steel hub</i> 	<ul style="list-style-type: none"> ■ Facilitates re-vulcanizing ■ Improved longevity and durability
<ul style="list-style-type: none"> ■ Drive Wheels <i>vulcanized natural traction surface</i> 	<ul style="list-style-type: none"> ■ Ensures positive traction ■ Maximizes wear life
<ul style="list-style-type: none"> ■ Idler Wheels <i>solid rubber c/w delrin bushings</i> 	<ul style="list-style-type: none"> ■ Requires no lubrication no maintenance ■ Easy replacement
<ul style="list-style-type: none"> ■ Clean In Place <i>Hand Adjustable Clip-On Spray Nozzles</i> 	<ul style="list-style-type: none"> ■ Facilitates easy cleaning ■ Spray pattern easily configured without tools
<ul style="list-style-type: none"> ■ Gearbox / Shaft Coupling <i>2 piece Stainless Steel Horizontal Split Configuration</i> 	<ul style="list-style-type: none"> ■ Provides smooth power transmission ■ Ensures ease of removal and assembly ■ Will not seize on the shaft