



Dry Solids for More Options

RP 36 ROLLER PRESS

The Accent RP 36 is a twin drum roller press used to wring out moisture from manure and produce dry solids for more options. Using a 3HP high torque vector drive the roller press can handle sand laden manure, hoof blocks and all the tough jobs with ease. Variable speed allows you to dial the RP36 to your exact needs. When coupled with the IFRS 36 Separator the combination becomes a stand alone manure management system.

STAINLESS STEEL CONSTRUCTION

Like all Accent products we use only the best materials available, 304 stainless steel, German engineered SEW gearboxes, high impact, non corrosive plastic components and mother nature's own virgin rubber. Machined, fitted and assembled to Accent Manufacturing's exacting standards, the RP 36 Roller Press promises to deliver unequalled service and performance.

SIMPLE. VERSATILE. DURABLE.

Simplicity, maintenance free components like Delrin bearings with brass oil lite bushings mean no more greasing. **Versatility**, built with oversized motors and gearboxes, there's always enough power even for the toughest jobs. **Durability**, the tough rubber gum roll and heavy duty stainless steel screen tackles any manure composition, including sand, head on.

www.accentmanufacturing.com



Accent Manufacturing Inc.
602 - 30731 Simpson Road, Abbotsford, British Columbia, Canada V2T 6Y7. Tel: 604.850.7799. Fax: 604.850.7909.
E-mail: info@accentmanufacturing.com

Accent RP36 Roller Press

PERFECTLY CALIBRATED TO GIVE YOU DRYER SOLIDS

Listed below are the many features and benefits of the Accent RP 36 Roller Press, the optional dryer unit for the IFRS 36 Separator. All Accent equipment is designed to work together to make the Accent Manure Management System versatile for multiple applications and durable for many years of trouble-free use. Careful attention to the things that really matter is what makes Accent the first choice for manure separation equipment around the world.

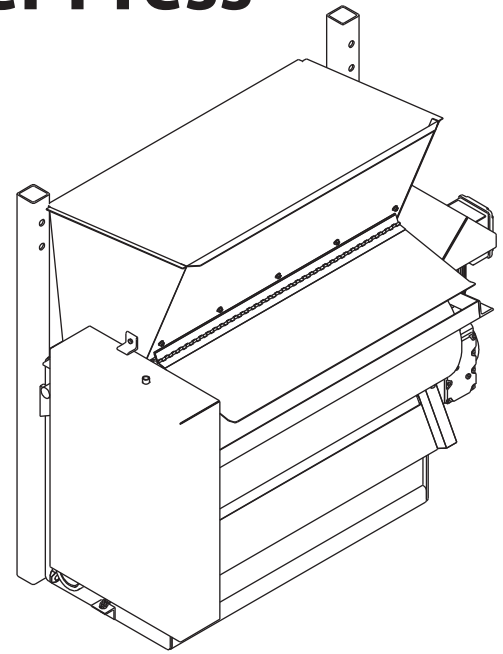

Features	Benefits
<ul style="list-style-type: none"> Stainless Steel Construction 	<ul style="list-style-type: none"> Non-corrosive long life
<ul style="list-style-type: none"> Vector Drive VFD Gearbox <i>Variable Speed Control & High Torque Starting</i> 	<ul style="list-style-type: none"> Provides speed control for fine tuning thru put rate Optimizes solid matter dewatering Provides extra torque when required to clear obstructions
<ul style="list-style-type: none"> Rubber Gum Roll 	<ul style="list-style-type: none"> Durable maximizes wear life Resistant to abrasion and damage from obstructions Facilitates re-vulcanizing
<ul style="list-style-type: none"> Screen Roll <i>(3/16" Perforated Stainless Steel)</i> 	<ul style="list-style-type: none"> Robust construction durable and long lasting High flow excellent dewatering
<ul style="list-style-type: none"> Serpentine Belt Drive 	<ul style="list-style-type: none"> Delivers superior torque to driven rolls to ensure positive rotation Facilitates obstruction ejection
<ul style="list-style-type: none"> Doctor Blade 	<ul style="list-style-type: none"> Keeps perf roll clear for drier solids
<ul style="list-style-type: none"> Delrin Engineered Bearings <i>One piece machined bearing blocks</i> 	<ul style="list-style-type: none"> Requires no lubrication Trouble- free operation Easy replacement and low cost
<ul style="list-style-type: none"> Sintered Bronze Bushing 	<ul style="list-style-type: none"> Requires no lubrication Trouble- free operation Easy replacement and low cost
<ul style="list-style-type: none"> Torque Arm Drive 	<ul style="list-style-type: none"> Isolates motor / gear drive Better cooling and longer life